

1 2 3 4 5 6 7 8

REVISIONS		
ISS	ZONE	DESCRIPTION\PER REQUEST\DATE

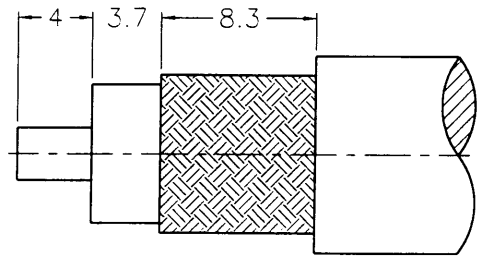

業務部

RECOMMENDED  
CABLE STRIPPING DIM'S

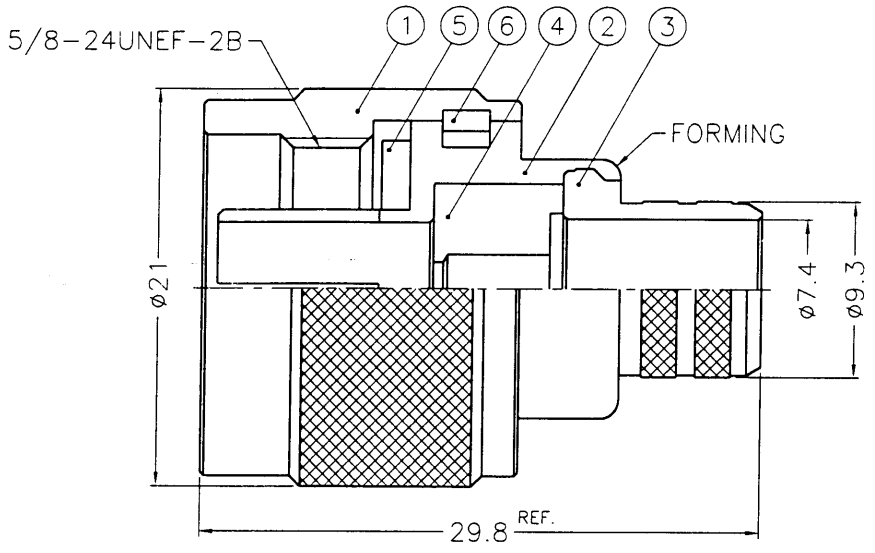
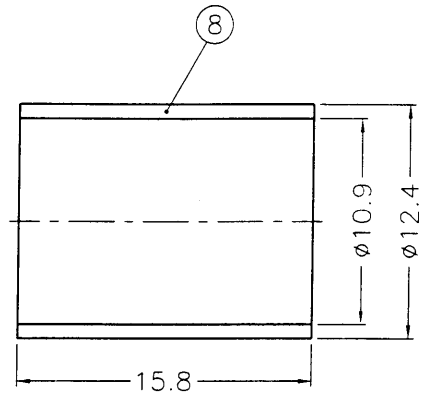
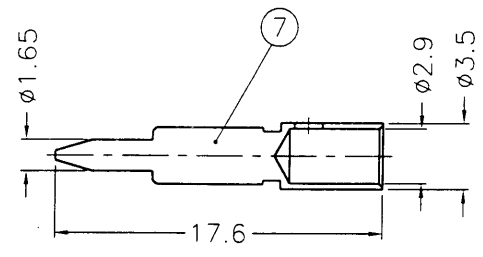

NOTES: FINISH (PLATING THICKNESS IN MICRO-INCHES)  
 1. BRASS PER QQ-B-626  
 2. NICKEL PL. 100 MIN. THICK OVER COPPER STRIKE  
 3. GOLD PL. 3 MIN. THICK OVER NICKEL PL. 100 MIN. THICK OVER COPPER STRIKE  
 4. TEFLON MIL-P-19468  
 5. JIS H 3250, C 2700

88.4.19  
R & D

NO.	DESCRIPTION	MATERIAL	FINISH	Q'TY	DRAWING NO.
8	FERRULE	NOTE 5	NOTE 2	1	FR-124/109X158
7	CONTACT PIN	NOTE 1	NOTE 3	1	N5201-11-35/29-C
6	RETAINER RING	SUS 304	NATURAL	1	N5000-7-C
5	GASKET	SILICONE	RED	1	GS-156/8X15
4	INSULATOR	NOTE 4	NATURAL	1	N5201-5T-50-9913
3	BARREL	NOTE 1	NOTE 2	1	N5000-3-93/74
2	BODY	NOTE 1	NOTE 2	1	N1121A2-2
1	SHELL	NOTE 1	NOTE 2	1	N5000-1-B

DIMENSIONS ARE IN MILLIMETERS  
 UNLESS OTHERWISE SPECIFIED TOLERANCES  
 0.5-6 = ±0.2  
 6-30 = ±0.4  
 30-120 = ±0.6  
 120-315 = ±1  
 315-1000 = ±1.6  
 1000-2000 = ±2.4

PART NO.	
APPROVED	DATE 04-15-99'
CHECKED	DATE 04-15-99'
DRAWN	DATE 04-15-99'

KAI JACK INDUSTRIAL CO., LTD. TAINAN TAIWAN R.O.C.	
TITLE	N CRIMP PLUG (FOR BELDEN 9913, 9914)
DRAWING NO.	KJ-N1121A2-NT3G-9913-50
FILE NO.	F:\DWG\N\1121A2\9913-50\NT3G

F  
E  
D  
C  
B  
A

F  
E  
D  
C  
B  
A

1 2 3 4 5 6 7 8 8N R16